



# TW-85KL

## Laser Projector



# 01

## APPEARANCE

**Model : TW-85KL**



# 02

## FUNCTIONAL FEATURES

### ❖ Fully enclosed structural design

TWT's enclosed optical engine reaches the IP6X international dust-proof level, and is adopted from the light source, optical engine to the circulating cooling air duct. The fully enclosed structure design effectively isolates dust intrusion and prevents the user from using the projector for a short period of time (about 500-1000 hours), which will cause the brightness of the image to decay by more than 50%, ensuring the image quality and stability of the projector.

### ❖ Long-lasting laser light source with a lifespan of 20,000 hours.

It adopts a stable and reliable laser light source with an ultra-long life of 20,000 hours. It is energy-saving and environmentally friendly. It saves more than 30% of electricity than ordinary projectors, significantly reducing maintenance costs.

### ❖ The super color filtering function

Filters out the noise that affects the image quality caused by blue, green, and red colors during the color mixing process according to the color presentation requirements of the picture, thereby improving color purity, and making the color more accurate and the image quality more delicate.

### ❖ Internal Circulating Cooling System

ICCS technology uses the enclosed cooling principle - the external cooling system and the internal loop cooling system, which keeps the internal optical system having a good constant temperature environment.

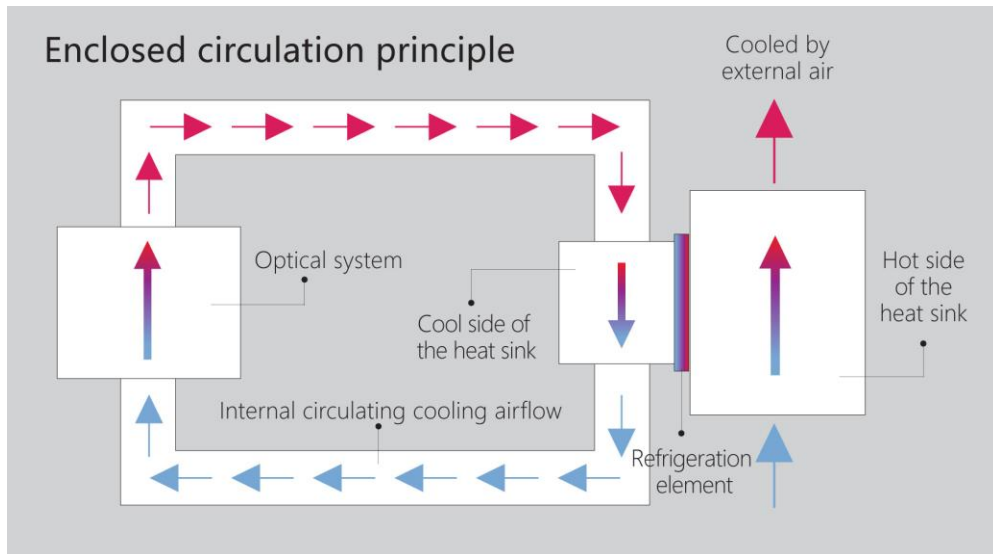

- ❖ Supports HDBaseT long-distance network transmission function
- ❖ Supports horizontal and vertical 360° rotation installation and automatic screen flip function
- ❖ Multiple image mode selections, supports DICOM simulation mode
- ❖ USB direct reading of pictures and Video function (mainly supported file formats for playback: MKV, MP4, AVI, JPEG, etc.)
- ❖ Dual USB, USB\*1 supports power output 2.5A to facilitate expansion of device supply Power; USB\*1 supports multimedia playback
- ❖ Quick power on and off function, power-off protection function
- ❖ Password lock and anti-theft function
- ❖ Supports Crestron, PJ-Link, AMX, with high-altitude mode
- ❖ Supports screen freezing, one-click black screen function
- ❖ Optional with zoom lens 0.68~0.80:1; fixed focus lens 0.31:1, 0.36:1, 0.55:1, 0.65:1, 0.67:1

<b>Model</b>	TW-85KL	
<b>Display Technology</b>	Liquid Crystal Display	
<b>LCD Panel</b>	3x0.64"	
<b>Brightness</b>	8500 Lumens	
<b>Resolution</b>	WUXGA (1920x1200)	
<b>Contrast</b>	3500000:1	
<b>Picture Uniformity</b>	≥ 90%	
<b>Lens</b>	F1.6~2.25, F=16.09~25.75mm, 1.6x Zoom Ratio	
<b>Throw Ratio</b>	1.14-1.86	
<b>Aspect Ratio</b>	16:10 (Compatible With 4:3)	
<b>Projection Distance (30~300")</b>	0.71-12.16m	
<b>Light Source</b>	Laser Diode	
<b>Light Source Life</b>	Normal Mode: 20000h, Economy Mode: 25000h	
<b>Optical Shift</b>	Vertical: +50% (Manual), Horizontal: ±10% (Manual)	
<b>Digital Keystone Correction</b>	Vertical: ±40° (Auto+manual), Horizontal: ±15° (Manual)	
<b>Input Interface</b>	Computer	VGA (D-sub 15pin) ×1
	Computer Sound Effects	Audio In: Mini Jack ×1 (3.5mm)
	Video	DVI X 1HDMI ×1video ×1 (RCA)
	Other Interfaces	USB ×2 / HDBaseTx1
<b>Output Interface</b>	VGA (D-sub 15pin) ×1audio Out: Mini-jack ×1 (3.5mm)	
<b>Control Interface</b>	RS232 (D-sub 9pin) ×1 , RJ-45 ×1 (Control)	
<b>Computer Signal</b>	VGA,SVGA,XGA,SXGA,WXGA,WUXGA,MXGA,MSXGA,WSXGA,UXGA,Mac	
<b>Video Input Signal</b>	PAL,SECAM,NTSC,480i,480p,565p,576p,576i,720p,1080i,1080p	
<b>Scanning Frequency</b>	Horizontal: 15~90kHz, Vertical: 24~85Hz	
<b>Noise</b>	Front Projection/Rear Projection, Desktop/Ceiling Mounting	
<b>Projection Method</b>	Normal Mode: 39db, Economy Mode: 35db	
<b>Trumpet</b>	10w×1	
<b>Weight</b>	12.2kg	

# 04

## SPECIFICATIONS

<b>Dimensions (Length × Width × Height)</b>	545 x 340 x 135mm (excluding protruding parts)
<b>Power Supply</b>	100~240V AC (50/60Hz)
<b>Machine Power Consumption</b>	550W max
<b>Standby Power Consumption</b>	≤0.5W
<b>Operation/Storage Temperature</b>	0°C~40°C / -10°C~60°C
<b>Operation/Storage Humidity</b>	20%~80% (no condensation) / 20%~80% (no condensation)
<b>Standard Equipment</b>	Chinese remote control, power cord, fast and dynamic card, certificate of quality, warranty card

# 05

## APPEARANCE SIZE

Unit: mm

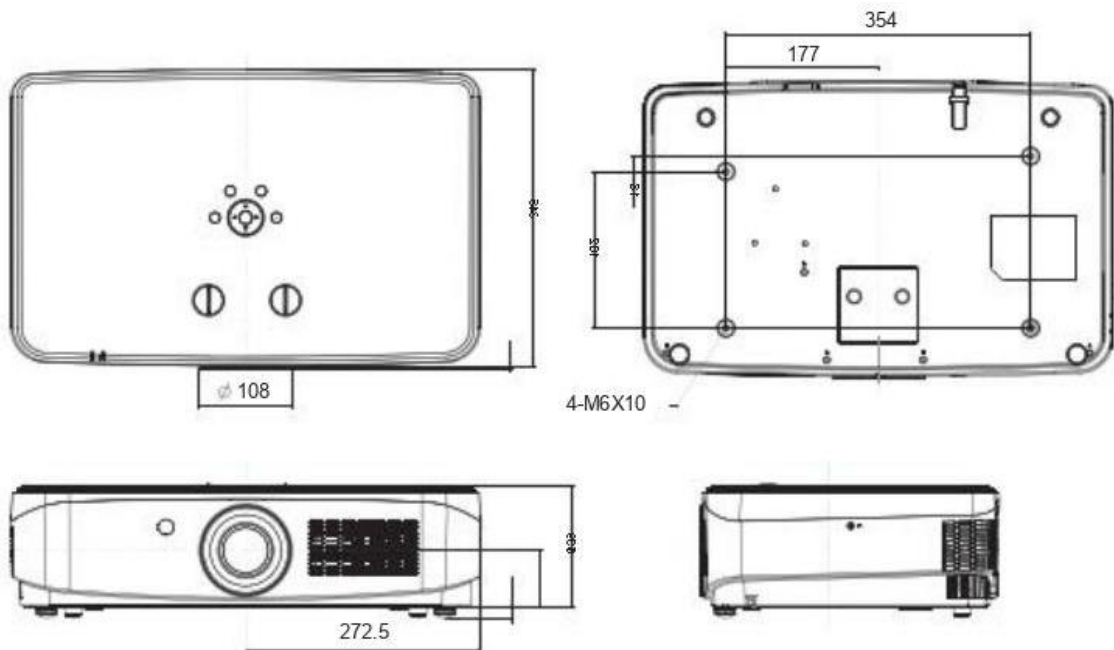

### TWT APPLIED TECHNOLOGY AND SERVICES PTE LTD

TWT reserves the right to change products' dimensions and specifications without notice  
 TWT APPLIED TECHNOLOGY AND SERVICES PTE LTD reserves the ultimate right to the interpretation of this catalogue.  
 ADDRESS : 71 BUKIT BATOK CRESCENT #09-04 PRESTIGE CENTRE SINGAPORE 658071  
 TEL : +65 9798 4332

