

RV4

RECEIVING CARD

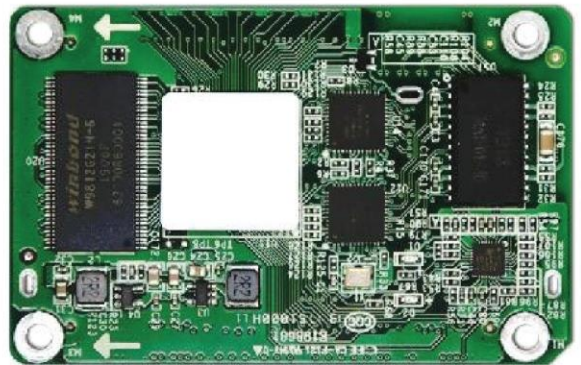

SPECIFICATION

Contents

<i>1 Introduction</i>	2
<i>2 Features</i>	3
Improvements to Display Effect	3
Improvements to Maintainability	5
Improvements to Reliability.....	6
Indicators.....	6
<i>3 Dimensions</i>	7
Pins	7
Pins for 32 Groups of Parallel Data	7
Reference Design for Extended Functions.....	13
<i>4 Specifications</i>	14



1 *Introduction*

- The RV4 is a high-end small receiving card developed by TWT. A single RV4 loads up to 512×256 pixels (PWM IC). Adopting the exclusive Image Booster Engine technology of TWT, the RV4 can precisely calibrate the color gamut and grayscale of the screen, and improve the grayscale by 64 times. It also supports the pixel level brightness and chroma calibration, individual Gamma adjustment for RGB, low latency, 3D and HDR functions, greatly improving the brightness, grayscale and color performance from every aspect and offering users an ultimate visual experience with a uniform, smooth and lifelike image.
- The RV4 uses high-density connectors for communication to limit the effects of dust and vibration, resulting in high stability. It supports up to 32 groups of parallel RGB data or 64 groups of serial data (expandable to 128 groups of serial data). Its reserved pins allow for custom functions of users. Thanks to its EMC Class B compliant hardware design, the RV4 has improved electromagnetic compatibility and is suitable to various on-site setups that have high requirements.
- Large loading capacity with a single RV4.
- Can read the RV4 parameter configuration: license date setting, operation time (lifetime) of RV4, current license.

2 Features

- 512×256 pixels (PWM IC), 384×256 pixels (Common IC)
- 32 RGB data out
- MOM Interface
- Pixel level color & brightness calibration
- Receiving Card Backup
- RCFG Backup & Read
- Auto Calibration
- Cabinet Mapping
- 18Bit+
- Clear View
- Free Rotation
- Low Latency
- HDR10-Optima / HLG

Improvements to Display Effect

- Image Booster Engine
The Image Booster Engine has the following 3 functions which improve the display effect (the actual effect depends on the driver IC) from different dimensions.
 - Color Management: Switch the color gamut of the screen between multiple gamuts to enable more precise colors on the screen.
 - Precise Grayscale: Individually correct the 65,536 levels of grayscale (16bit) of the driver IC to fix the display problems at low grayscale conditions, such as brightness spikes, brightness dips, color cast and mottling. This function can also better assist other display technologies, such as 18bit+ and individual Gamma adjustment for RGB, allowing for a smoother and uniform image.
 - 18bit+: Improve the LED display grayscale by 64 times to avoid grayscale loss due to low brightness and allow for more details in dark areas and a smoother image.

- Pixel level brightness and chroma calibration Working with App and App, the receiving card supports brightness and chroma calibration on each LED, which can effectively remove color discrepancies and greatly improve LED display brightness and chroma consistency, allowing for better image quality.
- Quick adjustment of dark or bright lines
The dark or bright lines caused by splicing of cabinets or modules can be adjusted to improve the visual experience. This function is easy to use and the adjustment takes effect immediately.
- Low latency
The latency of video source on the receiving card end can be reduced to 1 frame (only when using modules with driver IC with built-in RAM).
- 3D function
- Working with the independent controller which supports 3D function, the receiving card supports 3D image output.
- Individual Gamma adjustment for RGB Working with App and the independent controller which supports this function, the receiving card supports individual adjustment of red Gamma, green Gamma and blue Gamma, which can effectively control image non-uniformity under low grayscale and white balance offset, allowing for a more realistic image.
- Image rotation in 90° increments
The display image can be set to rotate in multiples of 90° (0°/90°/180°/270°).
- Image rotation at any angle
Working with the MCTRL R5 LED display controller and App, the receiving card supports image rotation at any angle.
- HDR
Supports HDR10 and HLG video sources.

Working with the independent controller which supports the HDR function, the receiving card can reproduce the original brightness range and color space of the video source, allowing for a more lifelike image.

Improvements to Maintainability

- Smart module (supported by dedicated firmware) Working with the smart module, the receiving card supports module ID management, storage of calibration coefficients and module parameters, monitoring of module temperature, voltage and flat cable communication status, LED error detection, and recording of the module run time.
- Automatic module calibration
After a new module with flash memory is installed to replace the old one, the calibration coefficients stored in the flash memory can be automatically uploaded to the receiving card when it is powered on.
- Module Flash management
For modules with flash memory, the information stored in the memory can be managed. The calibration coefficients and module ID can be stored and read back.
- One click to apply calibration coefficients stored in module Flash
For modules with flash memory, if the Ethernet cable is disconnected, users can hold down the self-test button on the cabinet to upload the calibration coefficients in the flash memory of the module to the receiving card.
- Mapping function
The cabinets display the receiving card number and Ethernet port information, allowing users to easily obtain the locations and connection topology of receiving cards.
- Setting of a pre-stored image in receiving card the image displayed on the screen during startup, or displayed when the Ethernet cable is disconnected or there is no video signal can be customized.
- Temperature and voltage monitoring
The temperature and voltage of the receiving card can be monitored without using peripherals.
- Cabinet LCD
The LCD module connected to the cabinet can display the temperature, voltage, single run time and total run time of the receiving card.
- Bit error rate monitoring
The Ethernet port communication quality of the receiving card can be monitored and the number of erroneous packets can be recorded to help troubleshoot network communication problems.
- Firmware program readback
The firmware program of the receiving card can be read back and saved to the local computer.
- Configuration parameter readback
The configuration parameters of the receiving card can be read back and saved to the local computer.
- LVDS transmission (supported by dedicated firmware)
Low-voltage differential signaling (LVDS) transmission is used to reduce the number of data cables from the hub board to module, increase the transmission distance, and improve the signal transmission quality and electromagnetic compatibility (EMC).

Improvements to Reliability

- **Dual card backup and status monitoring**
In an application with requirements for high reliability, two receiving cards can be mounted onto a single hub board for backup. In the case that the main receiving card fails, the backup card will serve to ensure uninterrupted operation of the display.
The working status of the main and backup receiving cards can be monitored in App V5.2.0 or later.
- **Status detection of dual power supplies**
When two power supplies are connected, their working status can be detected by the receiving card.
- **Loop backup**
The receiving cards and the sending card form a loop via the main and backup line connections. If a fault occurs at a location of the lines, the screen can still display the image normally.
- **Dual backup of configuration parameters**
The receiving card configuration parameters are stored in the application area and factory area of the receiving card at the same time. Users usually use the configuration parameters in the application area. If necessary, users can restore the configuration parameters in the factory area to the application area.
- **Dual backup of the application program**
Two copies of the application program are stored in the receiving card at the factory to avoid the problem that the receiving card may get stuck due to program update exception.
- **Dual backup of calibration coefficients**
The calibration coefficients are stored in the application area and factory area of the receiving card at the same time. Users usually use the calibration coefficients in the application area. If necessary, users can restore the calibration coefficients in the factory area to the application area.

Indicators

Indicator	Color	Status	Description
Running indicator	Green	Flashing once every 1s	The receiving card is functioning normally. Ethernet cable connection is normal, and video source input is available.
		Flashing once every 3s	Ethernet cable connection is abnormal.
		Flashing 3 times every 0.5s	Ethernet cable connection is normal, but no video source input is available.
		Flashing once every 0.2s	The receiving card failed to load the program in the application area and now is using the backup
		Flashing 8 times every 0.5s	A redundancy switchover occurred on the Ethernet port and the loop backup has taken effect.
Power indicator	Red	Always on	The power input is normal.

3 Dimensions

The board thickness is not greater than 2.0 mm, and the total thickness (board thickness + thickness of components on the top and bottom sides) is not greater than 8.0 mm. Ground connection (GND) is enabled for mounting holes.

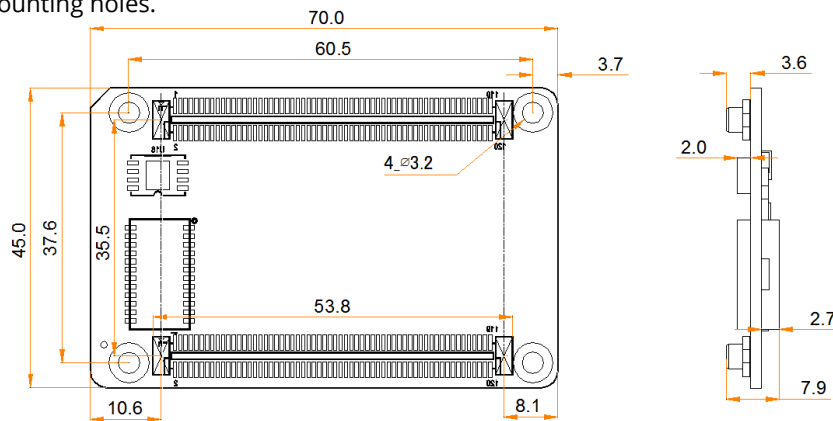

Tolerance: ± 0.1 Unit: mm

Pins

Pins for 32 Groups of Parallel Data

JH1				JH2			
VCC5.0	119	120	VCC5.0	GND	119	120	GND
	117	118		GND	117	118	GND
	115	116			115	116	
	113	114			113	114	
GND	X 111	112	GND		X 111	112	
GND	109	110	GND		X 109	110	
	X 107	108		GND	X 107	108	GND
	X 105	106		B16	105	106	G16
	X 103	104		R16	103	104	B16
	X 101	102		G16	101	102	R16
RFU18	99	100		B14	99	100	G14
RFU16	97	98	RFU17	R14	97	98	B13
GND	95	96	RFU15	G13	95	96	R13
RFU14	93	94	RFU13	GND	93	94	GND
RFU12	91	92	RFU11	B12	91	92	G12
RFU10	89	90	RFU9	R12	89	90	B11
RFU8	87	88	RFU7	G11	87	88	R11
RFU6	85	86	RFU5	B10	85	86	G10
RFU4	83	84	RFU3	R10	83	84	B9
GND	81	82	GND	G9	81	82	R9
B32	79	80	G32	GND	79	80	GND
R32	77	78	B31	B8	77	78	G8
G31	75	76	R31	R8	75	76	B7
B30	73	74	G30	G7	73	74	R7
R30	71	72	B29	B7	71	72	G7
G29	69	70	R29	R7	69	70	B6
GND	67	68	GND	G6	67	68	R6
B28	65	66	G28	GND	65	66	GND
R28	63	64	B27	B4	63	64	G4
G27	61	62	R27	R4	61	62	B3
B26	59	60	G26	G3	59	60	R3
R26	57	58	B25	B2	57	58	G2
G25	55	56	R25	R2	55	56	B1
GND	53	54	GND	G1	53	54	R1
B24	51	52	G24	GND	51	52	GND
R24	49	50	B23	OE BLUE	49	50	OE GREEN
G23	47	48	R23	E	47	48	OE RED
B22	45	46	G22	D	45	46	CTRL
R22	43	44	B21	C	43	44	LAT
G21	41	42	R21	B	41	42	DCLK 2
GND	39	40	GND	A	39	40	DCLK
B20	37	38	G20	GND	37	38	GND
R20	35	36	B19	TEST INPUT KEY	35	36	STA LED
G19	33	34	R19		33	34	
B18	31	32	G18		31	32	
R18	29	30	B17	Port1 T3-	X 29	30	Port2 T3-
G17	27	28	R17	Port1 T3+	27	28	Port2 T3+
GND	25	26	GND		25	26	
	X 23	24		Port1 T2-	X 23	24	Port2 T2-
GND	X 21	22		Port1 T2+	21	22	Port2 T2+
RFU2	19	20			19	20	
RFU1	17	18		Port1 T1-	X 17	18	Port2 T1-
EXT KEY	15	16		Port1 T1+	15	16	Port2 T1+
EXT_LCD_BL1	13	14			13	14	
EXT_LCD_BLD	11	12		Port1 T0-	X 11	12	Port2 T0-
EXT_LCD_SDA	9	10		Port1 T0+	9	10	Port2 T0+
EXT_LCD_SCL	7	8			7	8	
EXT_LCD_RS	5	6			5	6	
EXT_LCD_CS	3	4		Eth Shield	X 3	4	Eth Shield
GND	1	2	GND	Eth Shield	1	2	Eth Shield

IH1					
	GND	1	2	GND	
LCD CS signal	EXT LCD CS	3	4	NC	
LCD RS signal	EXT LCD RS	5	6	NC	
LCD clock signal	EXT LCD SCL	7	8	NC	
LCD data signal	EXT LCD SDA	9	10	NC	
LCD backlight signal 1	EXT LCD BL0	11	12	NC	
LCD backlight signal 2	EXT LCD BL1	13	14	NC	
LCD control button	EXT KEY	15	16	NC	
/	RFU1	17	18	NC	
/	RFU2	19	20	NC	
	GND	21	22	NC	
	NC	23	24	NC	
	GND	25	26	GND	
/	G17	27	28	R17	/
/	R18	29	30	B17	/
/	B18	31	32	G18	/
/	G19	33	34	R19	/
/	R20	35	36	B19	/
/	B20	37	38	G20	/
	GND	39	40	GND	
/	G21	41	42	R21	/
/	R22	43	44	B21	/
/	B22	45	46	G22	/
/	G23	47	48	R23	/
/	R24	49	50	B23	/
/	B24	51	52	G24	/
	GND	53	54	GND	
/	G25	55	56	R25	/
/	R26	57	58	B25	/
/	B26	59	60	G26	/
/	G27	61	62	R27	/
/	R28	63	64	B27	/
/	B28	65	66	G28	/
	GND	67	68	GND	
/	G29	69	70	R29	/
/	R30	71	72	B29	/
/	B30	73	74	G30	/
/	G31	75	76	R31	/
/	R32	77	78	B31	/
/	B32	79	80	G32	/
	GND	81	82	GND	
/	RFU4	83	84	RFU3	/
/	RFU6	85	86	RFU5	/
/	RFU8	87	88	RFU7	/
/	RFU10	89	90	RFU9	/
/	RFU12	91	92	RFU11	/
/	RFU14	93	94	RFU13	/
	GND	95	96	GND	
/	RFU16	97	98	RFU15	/
/	RFU18	99	100	RFU17	/
	NC	101	102	NC	
	NC	103	104	NC	
	NC	105	106	NC	
	NC	107	108	NC	
	GND	109	110	GND	
	GND	111	112	GND	
	NC	113	114	NC	
	VCC	115	116	VCC	
	VCC	117	118	VCC	
	VCC	119	120	VCC	

IH2					
Chassis ground	Eth Sheild	1	2	Eth Sheild	Chassis ground
Chassis ground	Eth Sheild	3	4	Eth Sheild	Chassis ground
	NC	5	6	NC	
	NC	7	8	NC	
Gigabit Ethernet port	Port1 T0+	9	10	Port2 T0+	Gigabit Ethernet port
	Port1 T0-	11	12	Port2 T0-	
	NC	13	14	NC	
	Port1 T1+	15	16	Port2 T1+	
	Port1 T1-	17	18	Port2 T1-	
	NC	19	20	NC	
	Port1 T2+	21	22	Port2 T2+	
	Port1 T2-	23	24	Port2 T2-	
	NC	25	26	NC	
	Port1 T3+	27	28	Port2 T3+	
	Port1 T3-	29	30	Port2 T3-	
	NC	31	32	NC	
	NC	33	34	NC	
Test button	TEST_INPUT_KEY	35	36	STA_LED-	Running indicator (active low)
	GND	37	38	GND	
Line decoding	A	39	40	DCLK	Shift clock output 1
Line decoding	B	41	42	DCLK 2	Shift clock output 2
Line decoding	C	43	44	LAT	Latch signal output
Line decoding	D	45	46	CTRL	Afterglow control
Line decoding	E	47	48	OE RED	Display enable
Display enable	OE BLUE	49	50	OE GREEN	Display enable
	GND	51	52	GND	
/	G1	53	54	R1	/
/	R2	55	56	B1	/
/	B2	57	58	G2	/
/	G3	59	60	R3	/
/	R4	61	62	B3	/
/	B4	63	64	G4	/
	GND	65	66	GND	
/	G5	67	68	R5	/
/	R6	69	70	B5	/
/	B6	71	72	G6	/
/	G7	73	74	R7	/
/	R8	75	76	B7	/
/	B8	77	78	G8	/
	GND	79	80	GND	
/	G9	81	82	R9	/
/	R10	83	84	B9	/
/	B10	85	86	G10	/
/	G11	87	88	R11	/
/	R12	89	90	B11	/
/	B12	91	92	G12	/
	GND	93	94	GND	
/	G13	95	96	R13	/
/	R14	97	98	B13	/
/	B14	99	100	G14	/
/	G15	101	102	R15	/
/	R16	103	104	B15	/
/	B16	105	106	G16	/

JH2					
	GND	107	108	GND	
	NC	109	110	NC	
	NC	111	112	NC	
	NC	113	114	NC	
	NC	115	116	NC	
	GND	117	118	GND	
	GND	119	120	GND	

Pins for 64 Groups of Serial Data

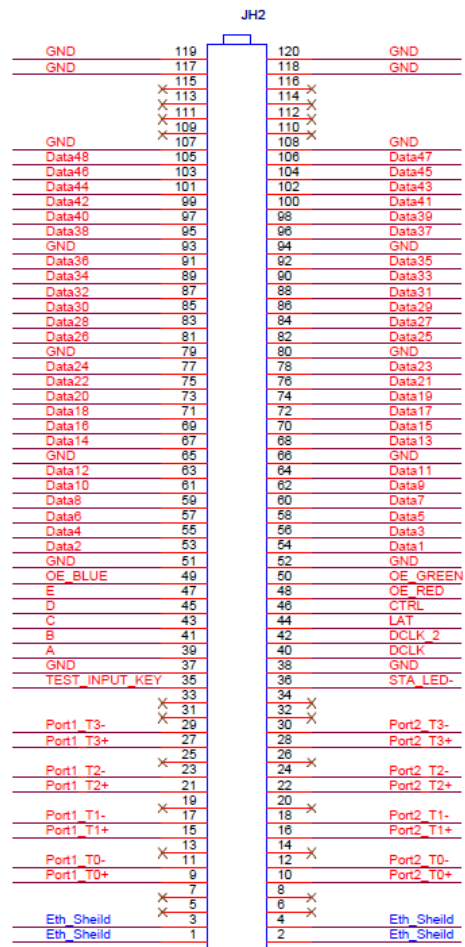
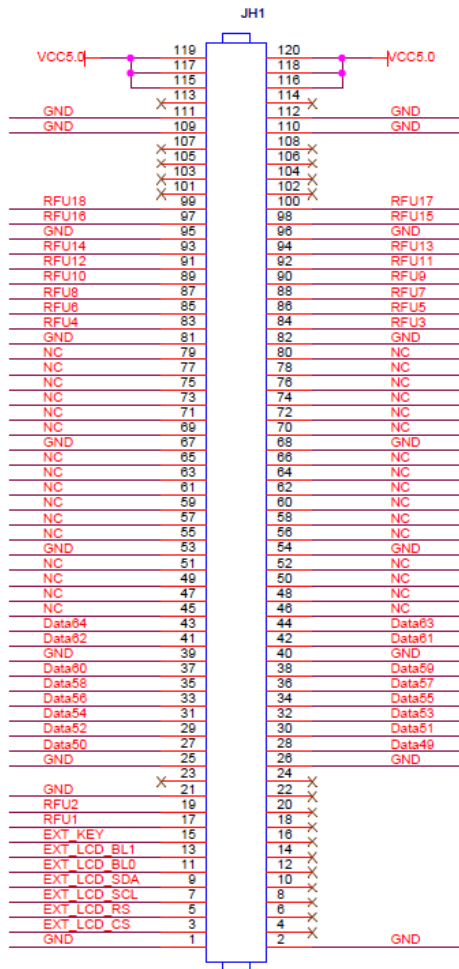

JH1					
	GND	1	2	GND	
LCD CS signal	EXT LCD CS	3	4	NC	
LCD RS signal	EXT LCD RS	5	6	NC	
LCD clock signal	EXT LCD SCL	7	8	NC	
LCD data signal	EXT LCD SDA	9	10	NC	
LCD backlight signal 1	EXT LCD BL0	11	12	NC	
LCD backlight signal 2	EXT LCD BL1	13	14	NC	
LCD control button	EXT KEY	15	16	NC	
/	RFU1	17	18	NC	
/	RFU2	19	20	NC	
	GND	21	22	NC	
	NC	23	24	NC	
	GND	25	26	GND	
/	Data50	27	28	Data49	/
/	Data52	29	30	Data51	/
/	Data54	31	32	Data53	/
/	Data56	33	34	Data55	/
/	Data58	35	36	Data57	/
/	Data60	37	38	Data59	/
	GND	39	40	GND	
/	Data62	41	42	Data61	/
/	Data64	43	44	Data63	/
	NC	45	46	NC	
	NC	47	48	NC	
	NC	49	50	NC	
	NC	51	52	NC	
	GND	53	54	GND	
	NC	55	56	NC	
	NC	57	58	NC	
	NC	59	60	NC	
	NC	61	62	NC	
	NC	63	64	NC	
	NC	65	66	NC	
	GND	67	68	GND	
	NC	69	70	NC	
	NC	71	72	NC	
	NC	73	74	NC	
	NC	75	76	NC	
	NC	77	78	NC	
	NC	79	80	NC	
	GND	81	82	GND	
/	RFU4	83	84	RFU3	/
/	RFU6	85	86	RFU5	/
/	RFU8	87	88	RFU7	/
/	RFU10	89	90	RFU9	/
/	RFU12	91	92	RFU11	/
/	RFU14	93	94	RFU13	/
	GND	95	96	GND	
/	RFU16	97	98	RFU15	/
/	RFU18	99	100	RFU17	/
	NC	101	102	NC	
	NC	103	104	NC	
	NC	105	106	NC	
	NC	107	108	NC	
	GND	109	110	GND	
	GND	111	112	GND	
	NC	113	114	NC	
	VCC	115	116	VCC	
	VCC	117	118	VCC	
	VCC	119	120	VCC	

Chassis ground	Eth Sheild	1	2	Eth_Sheild	Chassis ground
Chassis ground	Eth Sheild	3	4	Eth_Sheild	Chassis ground
	NC	5	6	NC	
	NC	7	8	NC	
Gigabit Ethernet port	Port1_T0+	9	10	Port2_T0+	Gigabit Ethernet port
	Port1_T0-	11	12	Port2_T0-	
	NC	13	14	NC	
	Port1_T1+	15	16	Port2_T1+	
	Port1_T1-	17	18	Port2_T1-	
	NC	19	20	NC	
	Port1_T2+	21	22	Port2_T2+	
	Port1_T2-	23	24	Port2_T2-	
	NC	25	26	NC	
	Port1_T3+	27	28	Port2_T3+	
Port1_T3-	29	30	Port2_T3-		
	NC	31	32	NC	
	NC	33	34	NC	
Test button	TEST_INPUT_KEY	35	36	STA_LED-	Running indicator (active low)
	GND	37	38	GND	
Line decoding signal	A	39	40	DCLK	Shift clock output 1
Line decoding signal	B	41	42	DCLK_2	Shift clock output 2
Line decoding signal	C	43	44	LAT	Latch signal output
Line decoding signal	D	45	46	CTRL	Afterglow control signal
Line decoding signal	E	47	48	OE_RED	Display enable
Display enable	OE_BLUE	49	50	OE_GREEN	Display enable
	GND	51	52	GND	
/	Data2	53	54	Data1	/
/	Data4	55	56	Data3	/
/	Data6	57	58	Data5	/
/	Data8	59	60	Data7	/
/	Data10	61	62	Data9	/
/	Data12	63	64	Data11	/
	GND	65	66	GND	
/	Data14	67	68	Data13	/
/	Data16	69	70	Data15	/
/	Data18	71	72	Data17	/
/	Data20	73	74	Data19	/
/	Data22	75	76	Data21	/
/	Data24	77	78	Data23	/
	GND	79	80	GND	
/	Data26	81	82	Data25	/
/	Data28	83	84	Data27	/
/	Data30	85	86	Data29	/
/	Data32	87	88	Data31	/
/	Data34	89	90	Data33	/
/	Data36	91	92	Data35	/
	GND	93	94	GND	
/	Data38	95	96	Data37	/
/	Data40	97	98	Data39	/
/	Data42	99	100	Data41	/
/	Data44	101	102	Data43	/
/	Data46	103	104	Data45	/
/	Data48	105	106	Data47	/
	GND	107	108	GND	
	NC	109	110	NC	
	NC	111	112	NC	
	NC	113	114	NC	
	NC	115	116	NC	
	GND	117	118	GND	
	GND	119	120	GND	

 **Note**

The recommended VCC power input is 5.0 V.

OE_RED, OE_GREEN and OE_BLUE are display enable pins. When RGB are not controlled separately, use OE_RED. When the PWM chip is used, those pins are used as GCLK pins.

In the mode of 128 groups of serial data, Data65–Data128 use the data of Data1–Data64, respectively.

Reference Design for Extended Functions

Pins for Extended			
Pin	Recommended Smart Module	Recommended Module Flash	Description
RFU1	Reserved	Reserved	A reserved pin for connection to
RFU2	Reserved	Reserved	A reserved pin for connection to
RFU3	HUB_CODE0	HUB_CODE0	Flash control pin 1
RFU4	HUB_SPI_CLK	HUB_SPI_CLK	Clock signal of serial pin
RFU5	HUB_CODE1	HUB_CODE1	Flash control pin 2
RFU6	HUB_SPI_CS	HUB_SPI_CS	CS signal of serial pin
RFU7	HUB_CODE2	HUB_CODE2	Flash control pin 3
RFU8	/	HUB_SPI_MOSI	Module Flash data storage input
	HUB_UART_TX	/	Smart module TX signal
RFU9	HUB_CODE3	HUB_CODE3	Flash control pin 4
RFU10	/	HUB_SPI_MISO	Module Flash data storage output
	HUB_UART_RX	/	Smart module RX signal
RFU11	HUB_H164_CSD	HUB_H164_CSD	74HC164 data signal
RFU12	/	/	/
RFU13	HUB_H164_CLK	HUB_H164_CLK	74HC164 clock signal
RFU14	POWER_STA1	POWER_STA1	Dual power supply detection signal
RFU15	MS_DATA	MS_DATA	Dual card backup connection signal
RFU16	POWER_STA2	POWER_STA2	Dual power supply detection signal
RFU17	MS_ID	MS_ID	Dual card backup identifier signal
RFU18	HUB_CODE4	HUB_CODE4	Flash control pin 5

 **Note**

The RFU8 and RFU10 are signal multiplex extension pins. Only one pin from either the Recommended Smart Module Pin or the Recommended Module Flash Pin can be selected at the same time.

4 Specifications

Maximum Resolution	512×256 pixels (IC PWM)	
Loading Capacity	384×256 pixels (IC Common)	
Electrical Parameters	Input voltage	DC 3.3 V to 5.5 V
	Rated current	0.6 A
	Rated power	3.0 W
Operating Environment	Temperature	-20°C to +70°C
	Humidity	10% RH to 90% RH, non-condensing
Storage Environment	Temperature	-25°C to +125°C
	Humidity	0% RH to 95% RH, non-condensing
Physical Specifications	Dimensions	70.0 mm × 45.0 mm × 7.3 mm
	Net weight	17.3 g
Packing Information	Packing specifications	An antistatic bag and anti-collision foam are provided for each receiving card. Each packing box contains 40 receiving cards.
	Packing box dimensions	378.0 mm × 190.0 mm × 120.0 mm
Certifications	RoHS, EMC Class B	



TWT APPLIED TECHNOLOGY AND SERVICES PTE LTD

TWT reserves the right to make product appearance , dimensions and specifications alternations.

TWT APPLIED TECHNOLOGY AND SERVICES PTE LTD reserves the ultimate right to the interpretation of this catalogue.

ADDRESS : 68 SUNGEI KADUT LOOP# 06 - 01 NUTZ CENTER , SINGAPORE 729504

TEL : +65 6367 3272 FAX : +65 6367 0763